

OtalgiaFX

BC182L

FUZZ

Build Guide
October 2019

www.otalgiafx.co.uk

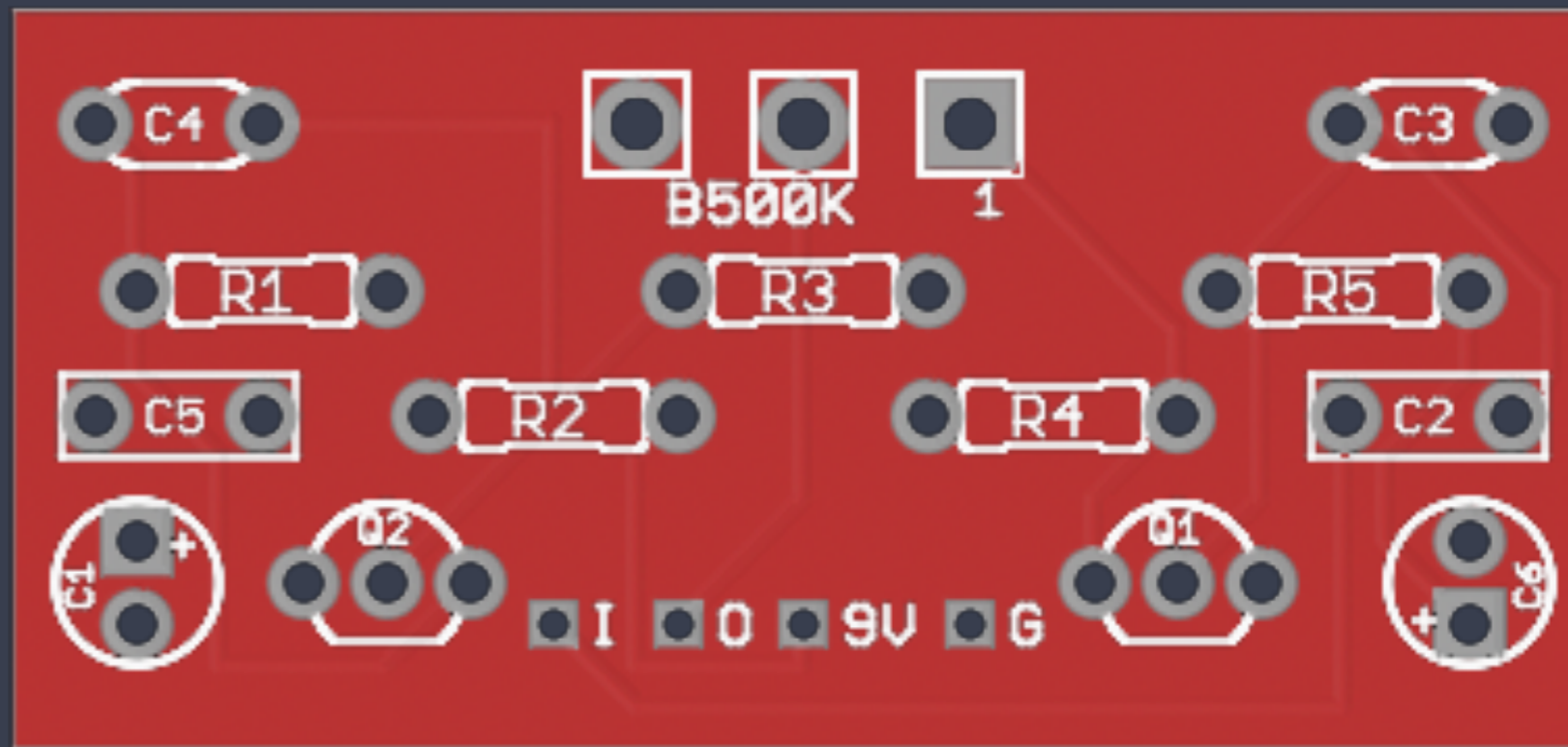

“Meaty fuzz in both standard and dark flavours”

BILL OF REQUIREMENTS

PART LIST

** Please note that this some of the parts in this list are interchangeable. For example you can use carbon resistors instead of metal film, however it is possible that changing these components might alter the sound slightly.

PART	VALUE	DEVICE TYPE
CAPACITORS		
C1	47uF	Polarised Electrolytic, 25v (or higher)
C2	10nf	5mm Polyester Box, 63v (or higher)
C3	470pf	Ceramic, 50v (or higher)
C4	47pf	Ceramic, 50v (or higher)
C5	22nf	5mm Polyester Box, 63v (or higher)
C6	10uF	Polarised Electrolytic, 25v (or higher)
** If building the "Dark" version then change C2 to 47nf and change C5 to 100nf		
RESISTORS		
R1	18K	1/4W Through Hole, Metal Film
R2	820 OHM	1/4W Through Hole, Metal Film
R3	4K7	1/4W Through Hole, Metal Film
R4	1K	1/4W Through Hole, Metal Film
R5	120K	1/4W Through Hole, Metal Film
TRANSISTORS		
Q1	2N3904	
Q2	BC182L	

BILL OF REQUIREMENTS

PART LIST (CTD)

PART	VALUE	DEVICE TYPE
POTENTIOMETERS		
VOL	B500K	16mm Linear, Pin Terminals

BUILDERS NOTES

In the parts list each component has a component number. This number corresponds to the placement number silk screen printed on the top of the PCB. Components should be mounted on the printed side of the PCB and soldered into place on the underside of the board.

To aid in construction and make soldering easier it is suggested that components are soldered to the board in order of their height profile from low to high, starting with resistors, diodes and then progressing on to larger items such as sockets and capacitors. The potentiometer should be soldered last.

Some items may require correct orientation for the circuit to work correctly as documented below -

Polarised Capacitors -

The PCB will have a "+" mark printed. This mark indicates where the positive lead of the capacitor should be soldered. In general the positive lead of a polarised capacitor is longer than the negative. Also in many polarised capacitors the body of the component will be marked to indicate the polarity of each lead.

Non Polarised Capacitors-

Non-Polarised capacitors can be mounted either way around.

Resistors -

Resistors are not polarised so can be mounted either way around.

BUILDERS NOTES (CTD)

Transistors-

The transistors will need to be orientated correct and match the placement image marked on the PCB. If you intend to use transistors that differ from the build list then please be aware than the Collector, Base and Emitter legs may be in a different order. The pinout legs of different transistors can be found by referring to their technical data sheets on the Web.

It is also worth noting that transistors are susceptible to heat damage so take care when soldering. Alternatively use transistor sockets and insert the transistors after the sockets have been soldered into place.

Potentiometer -

The potentiometer should be mounted onto the topside of the PCB with it splined shaft facing outwards.

Please refer to the picture later in this document if in doubt.

BUILDERS NOTES (CTD)

When mounting this circuit into an enclosure the potentiometer will hold the PCB in place within the enclosure and stop the circuit board from moving around. Please take care when mounting the potentiometer not to over tighten the nut or you might damage the potentiometers thread.



TESTING THE CIRCUIT

Before proceeding to the off board wiring of switches and LED's it is advised to test that the circuit is working as expected. To do this you need to solder four wires from the connectors on the PCB, marked I,O,9V & G.

The connectors are sized to accommodate AWG24 Single Strand Wire. If using this wire be careful not over bend it as it may snap. If you are not comfortable with handling single core wire then stranded may also be used.

To test your circuit -

1. Unplug the power supply
2. Plug a mono guitar cable into your guitar and a second mono guitar cable into your amplifier
3. Connect the wire from I (This is the input wire) to the tip of your guitar cable
4. Connect the wire from O (This is the output wire) to tip of your amp cable
5. Connect the wire from 9V (This is the Voltage wire) to the +9V of your power supply
6. Connect the wire from G (This is the Ground wire) to the sleeve of your guitar cable, the sleeve of the amp cable and to the Ground wire of your power supply.
7. Plug in the power supply and test the circuit is working. If it is then you can proceed to off board wiring.

The easiest way to perform off board wiring is to use a 3PDT switch daughterboard -

<https://www.otalgiafx.co.uk/wp-content/uploads/2017/09/3PDT-Instructions.pdf>

SCHEMATIC

