

OtalgiaFX

TL061

BOOST

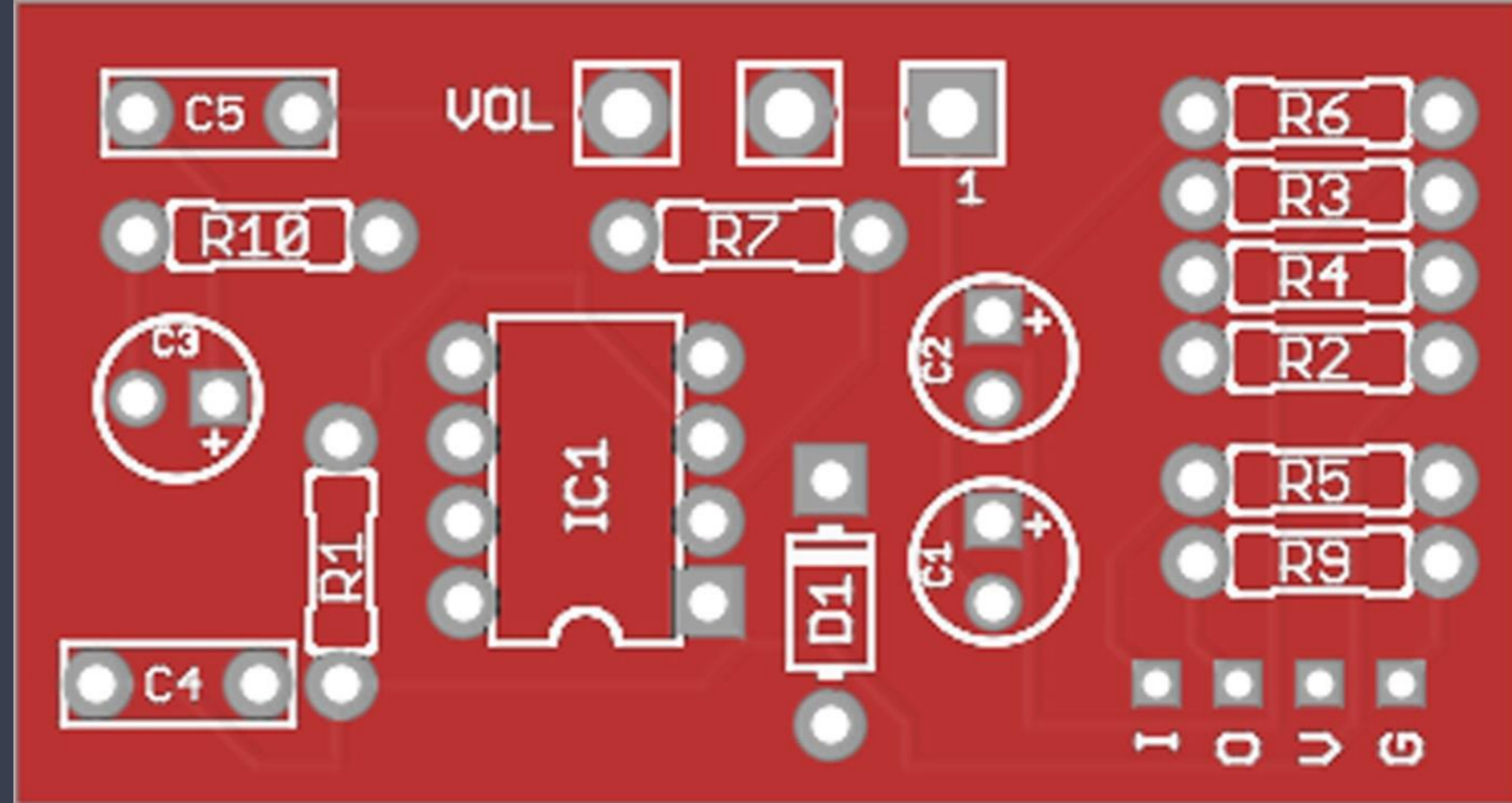

“ A low part count and easy to build op-amp based boost circuit”

Build Guide
October 2019

www.otalgiafx.co.uk

BILL OF REQUIREMENTS

PART LIST

** Please note that this some of the parts in this list are interchangeable. For example you can use carbon resistors instead of metal film, however it is possible that changing these components might alter the sound slightly.

PART	VALUE	DEVICE TYPE
CAPACITORS		
C1	1uF	Polarized Electrolytic, 25v (or higher)
C2	4u7	Polarized Electrolytic, 25v (or higher)
C3	15uf	Polarized Electrolytic, 25v (or higher)
C4	100nf	5mm Polyester Box, 63v (or higher)
C5	47pf	Ceramic, 50v (or higher)
DIODES		
D1	1N4001	1Amp Axial
INTEGRATED CIRCUIT		
IC1	TL061	Single Op-Amp IC - 8 pin DIL
RESISTORS		
R1	1K	1/4W Through Hole, Metal Film
R2	10M	1/4W Through Hole, Metal Film
R3	100K	1/4W Through Hole, Metal Film
R4	100K	1/4W Through Hole, Metal Film
R5	1M	1/4W Through Hole, Metal Film
R6	2K7	1/4W Through Hole, Metal Film

BILL OF REQUIREMENTS

PART LIST (CTD)

PART	VALUE	DEVICE TYPE
RESISTORS (CTD)		
R7	56K	1/4W Through Hole, Metal Film
R9	10K	1/4W Through Hole, Metal Film
R10	470 OHM	1/4W Through Hole, Metal Film
POTENTIOMETER		
VOL	C500K	16mm Reverse Logarithmic, Pin Terminals

BUILDERS NOTES

In the parts list each component has a component number. This number corresponds to the placement number silk screen printed on the top of the PCB. Components should be mounted on the printed side of the PCB and soldered into place on the underside of the board.

To aid in construction and make soldering easier it is suggested that components are soldered to the board in order of their height profile from low to high, starting with resistors, diodes and then progressing on to larger items such as sockets and capacitors. The potentiometer should be soldered last.

Some items may require correct orientation for the circuit to work correctly as documented below -

Polarised Capacitors -

The PCB will have a "+" mark printed. This mark indicates where the positive lead of the capacitor should be soldered. In general the positive lead of a polarised capacitor is longer than the negative. Also in many polarised capacitors the body of the component will be marked to indicate the polarity of each lead.

Integrated Circuits (IC) -

When mounting an integrated circuit to a board it is strongly recommended that a IC socket is used. This helps in several ways as it 1) Allows easy removal of the IC should it become damaged 2) Makes re-orientation possible (assuming mis-orientation hasn't damaged the IC) and 3) Prevents excessive heat damaging the chip whilst being soldered. If using a socket then solder the socket to the PCB BEFORE fitting the IC into the socket to avoid damage.

Please note that IC's are both heat and static electricity sensitive so take care when handling.

BUILDERS NOTES (CTD)

The IC needs to be orientated correctly. The PCB will show a half moon shaped notch printed where an IC is mounted. The IC should also have a notch on its body that needs to be aligned with the PCB's marking. If the IC doesn't have a notch on its body then please refer to the IC manufacturers documentation for further help.

Diodes -

A diode has 2 sides - a Cathode and Anode. The Cathode side of a diode has a circular band printed around the body of the component to aid identification. The PCB is printed to also showing this this marking to aid correct orientation. Diodes are sensitive to heat so take care when soldering, or alternatively consider use of sockets for mounting.

Resistors -

Resistors are not polarised so can be mounted either way around.

Non Polarised Capacitors-

Non-Polarised capacitors can be mounted either way around.

Potentiometer -

The potentiometer should be mounted onto the topside of the PCB with it splined shaft facing outwards.

Please refer to the picture later in this document if in doubt.

BUILDERS NOTES (CTD)

When mounting this circuit into an enclosure the potentiometer will hold the PCB in place within the enclosure and stop the circuit board from moving around. Please take care when mounting the potentiometer not to over tighten the nut or you might damage the potentiometers thread.

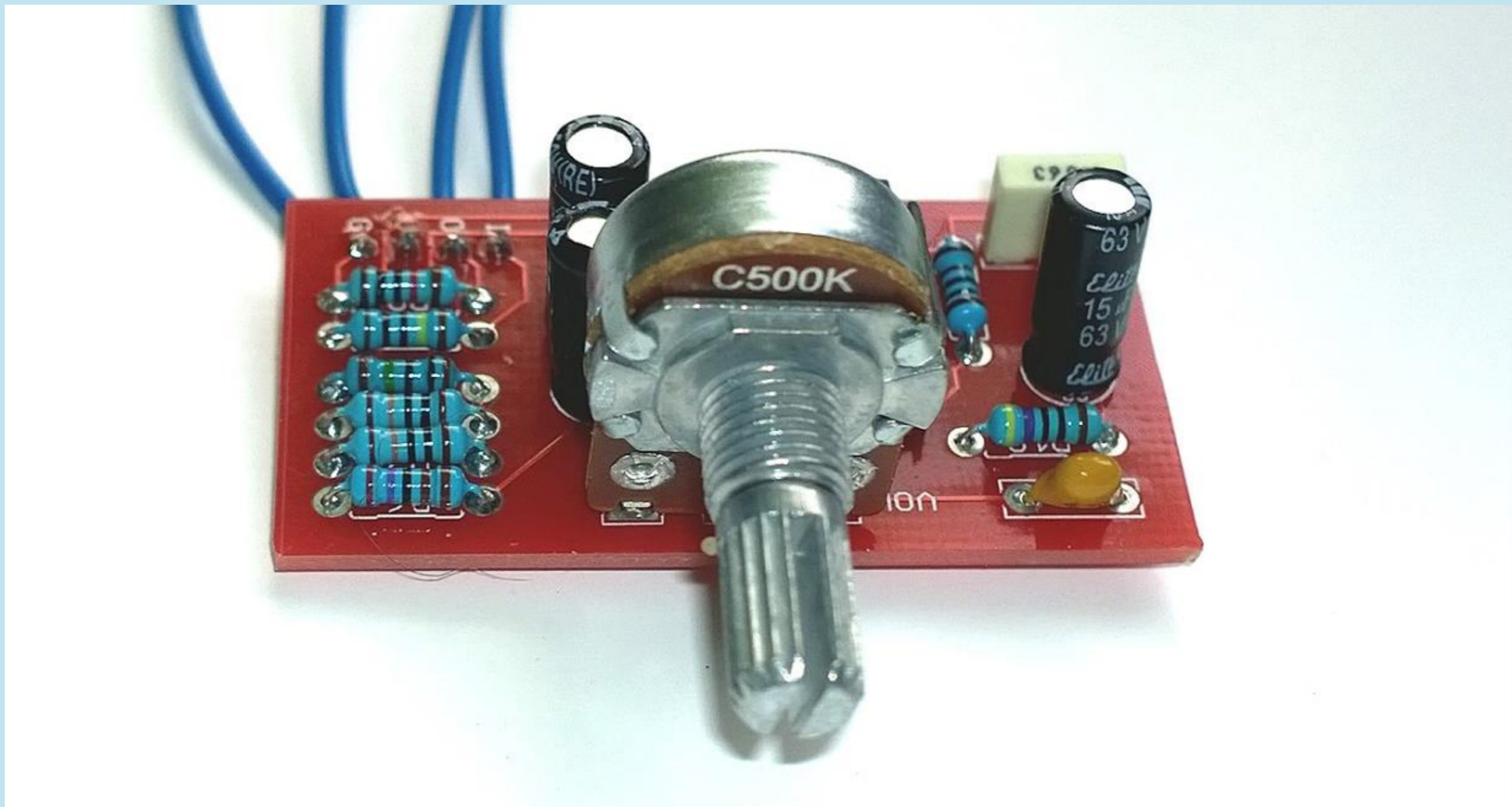

TESTING THE CIRCUIT

Before proceeding to the off board wiring of switches and LED's it is advised to test that the circuit is working as expected. To do this you need to solder four wires from the connectors on the PCB, marked I,O,9V & G.

The connectors are sized to accommodate AWG24 Single Strand Wire. If using this wire be careful not over bend it as it may snap. If you are not comfortable with handling single core wire then stranded may also be used.

To test your circuit -

1. Unplug the power supply
2. Plug a mono guitar cable into your guitar and a second mono guitar cable into your amplifier
3. Connect the wire from I (This is the input wire) to the tip of your guitar cable
4. Connect the wire from O (This is the output wire) to tip of your amp cable
5. Connect the wire from 9V (This is the Voltage wire) to the +9V of your power supply
6. Connect the wire from G (This is the Ground wire) to the sleeve of your guitar cable, the sleeve of the amp cable and to the Ground wire of your power supply.
7. Plug in the power supply and test the circuit is working. If it is then you can proceed to off board wiring.

The easiest way to perform off board wiring is to use a 3PDT switch daughterboard -

<https://www.otalgiafx.co.uk/wp-content/uploads/2017/09/3PDT-Instructions.pdf>

SCHEMATIC

